



Tripod CrystalLine

The new reflecta CrystalLine Tripods are characterized by the very good Price/Performance ratio. The tripod and tube colour is totally black which looks very modern and can be used for Home Cinema. The high quality fabric gives a brilliant image to the viewer.

Product details:

- Black metal tube, 6 cm diameter.
- Ergonomically designed carrying handle with lock.
- Continuously adjustable height of horizontal tube and telescopic tube.
- Projection screen can be rotated by 360°.
- Integrated keystone eliminator to incline the screen.
- Projection screen in BetaLux, matte white, 1.0 gain and wide viewing angle.
- Light-proof black rear side.
- Continuous black border.
- Optional carrying bags available for all sizes.

Tripod CrystalLine – Technical data (all dimensions in cm)

Ref.No.	Type	Fabric	Format	A	B	C	D	R1	R2	R3	E	F	G	H max.	H min.	Weight
87654	CrystalLine	BetaLux	1:1	125	125	121	121	2	2	2	129	6	6	193	168	8 kg
87650	CrystalLine	BetaLux	1:1	160	160	156	156	2	2	2	164	6	6	247	203	9 kg
87651	CrystalLine	BetaLux	1:1	180	180	176	176	2	2	2	184	6	6	268	223	10 kg
87652	CrystalLine	BetaLux	1:1	200	200	196	196	2	2	2	204	7	7	288	243	12 kg
87653	CrystalLine	BetaLux	1:1	240	240	236	236	2	2	2	244	7	7	308	263	13 kg

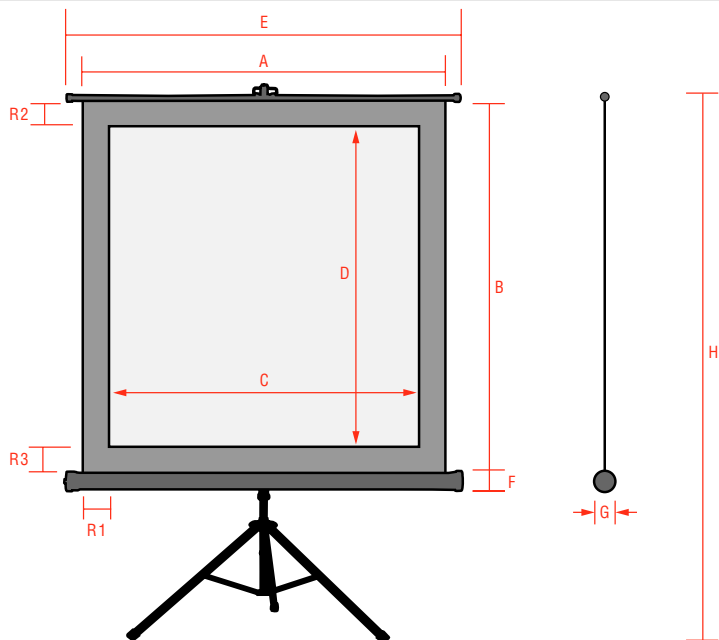

Fitting carrying bags available for all tripod projection screens.

Carrying bags for projection screens

50610	125 x 125 cm
50611	155 x 155 cm
50612	180 x 180 cm
50613	200 x 200 cm
50614	260 cm



Keystone eliminator